



JOCHC15B-W8

Rev.A.1.0

DESCRIPTION:

The products are 15MBd high-speed opto-couplers in a plastic WSOP8 package. The device consists of a 850 nm AlGaAS LED, optically coupled to a very high speed integrated photo-detector logic gate with a strobable output. The output end of the product is a CMOS output, and the product has a strong common mode rejection capability. The coupled parameters are guaranteed over the temperature range of -40°C to +110°C. The products are widely used in communication interface, digital isolation for A/D, D/A conversion, high-voltage power systems, renewable energy inverters, medical imaging and patient monitoring.

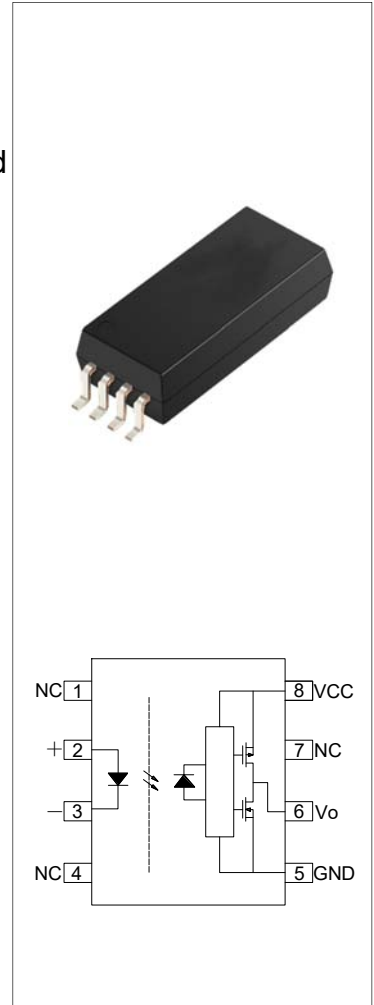

MAIN FEATURES

- High isolation 7500 VRMS
- High speed – 15MBd typical
- Operating temperature range -40°C to 110°C
- REACH & RoHS compliance
- HBM: H3A; MM: M4; CDM: C3
- CQC approved
- VDE approved
- UL approved

Truth Table

LED	Output
ON	L
OFF	H

ABSOLUTE MAXIMUM RATINGS (Temperature=25°C)

Parameter		Symbol	Value	Unit
Input	Forward Current	I_F	50	mA
	Peak Forward Current	I_{FP}	1 ^①	A
	Reverse Voltage	V_R	6	V

	Input Power Dissipation	P_D	100	mW
Output	Supply Voltage	V_{CC}	7	V
	Output Voltage	V_O	$V_{CC}+0.5$	V
	Output Current	I_O	10	mA
	Output Power Dissipation	P_O	22	mW
Total Power Dissipation		P_{tot}	130	mW
Isolation Voltage		V_{iso}	7500 ^②	Vrms
Operating Temperature		T_{opr}	-40~110	°C
Junction Temperature		T_j	125	°C
Storage Temperature		T_{stg}	-55~125	°C
Soldering Temperature		T_{sol}	260	°C

NOTE1: 100μs pulse, 100Hz frequency

NOTE2: AC for 1minute, R.H.=40~60%

ELECTRICAL CHARACTERISTICS (Temperature=25°C)

Parameter		Symbol	Condition	Min.	Typ.	Max.	Unit
Input	Forward Voltage	V_F	$I_F=10mA$	-	1.35	1.6	V
	Input Reverse Breakdown Voltage	BV_R	$I_R=10\mu A$	5	-	-	V
	Reverse Current	I_R	$V_R=6V$	-	-	1	μA
	Input Capacitance	C_{in}	$V=0, f=1MHz$	-	30	100	pF
Output	High Level Supply Current	I_{CCH}	$V_{CC}=5V, I_F=0mA$	-	-	6.5	mA
	Low Level Supply Current	I_{CCL}	$V_{CC}=5V, I_F=10mA$	-	-	6.5	mA
	Logic High Output Voltage	V_{OH}	$I_F=0mA, I_O=-20\mu A$	$V_{DD-0.1}$	V_{DD}	-	V
	Logic Low Output Voltage	V_{OL}	$I_F=7mA, I_O=20\mu A, V_{CC}=5V$	-	0.02	0.1	V
	Isolation Resistance	R_{ISO}	DC500V 40~60%R.H.	10^{12}	-	-	Ω
	Floating Capacitance	C_{IO}	$f=1MHz$	-	0.6	-	pF
Switching Characteristics	Trigger LED Current	I_{FT}	$V_{CC}=5V$	-	-	5	mA
	Propagation Delay	TPHL	$I_F=7mA, C_L=15pF$	-	70	100	ns

	Time to Logic Low						
	Propagation Delay Time to Logic High	TPLH	$I_F=7mA, C_L=15pF$	-	55	100	ns
	Common Mode Transient Immunity at Logic High	CM _H	$I_F=0mA,$ $V_{CM}=1000V_{pp},$ $C_L=15pF,$ $V_{CC}=5V$	20	-	-	kV/ μ s
	Common Mode Transient Immunity at Logic Low	CM _L	$I_F=7mA,$ $V_{CM}=1000V_{pp},$ $C_L=15pF,$ $V_{DD}=5V$	20	-	-	kV/ μ s

Recommended Operating Conditions

Characteristics	Symbol	Min.	Typ.	Max.	Unit
Operating Temperature	T_a	-40	-	105	$^{\circ}C$
Supply Voltage	V_{CC}	2.7	-	5.5	V
Low Level Input Current	I_{FL}	0	-	250	μA
High Level Input Current	I_{FH}	8	-	16	mA
Forward Voltage	$V_{F(OFF)}$	-	-	0.8	V

ORDERING INFORMATION

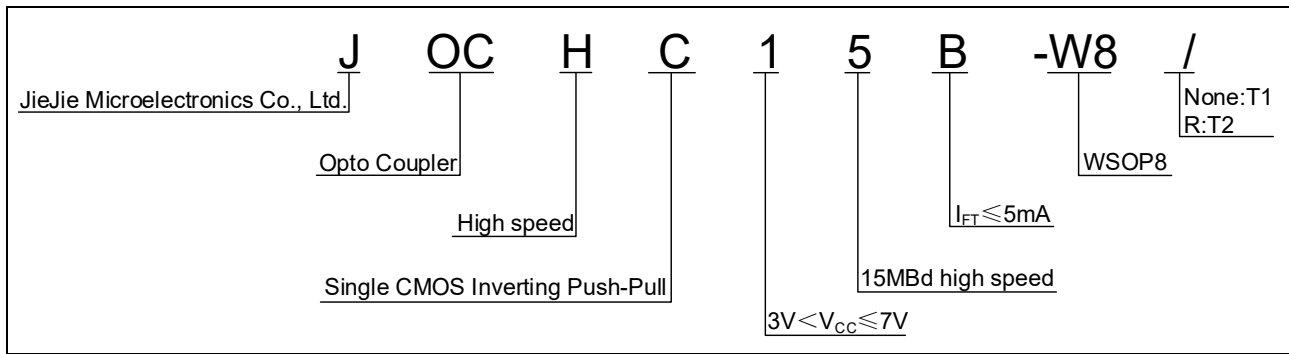

Packing Quantity	
Option	Quantity
None/R	1200 Units/Reel

MARKING

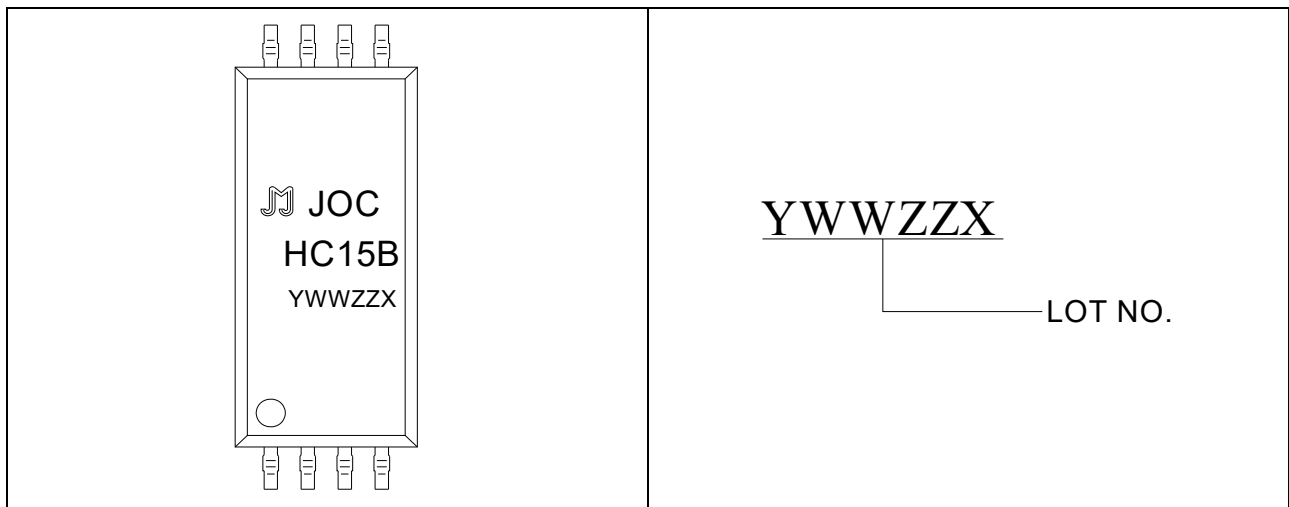

Characteristics Curves

FIG.1: Forward Current vs. Forward Voltage

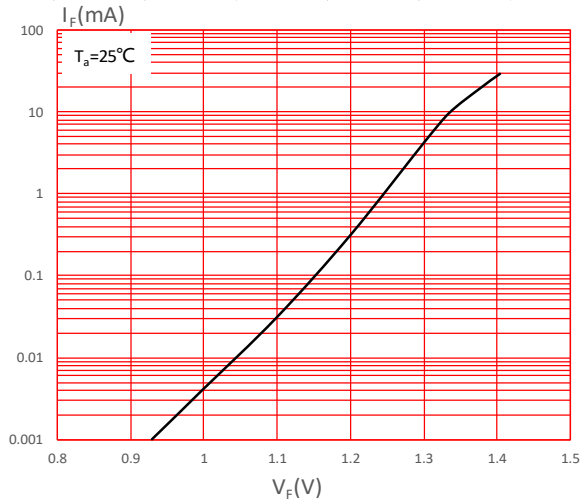

FIG.2: Max. Allowable LED Forward Current vs. Ambient Temperature

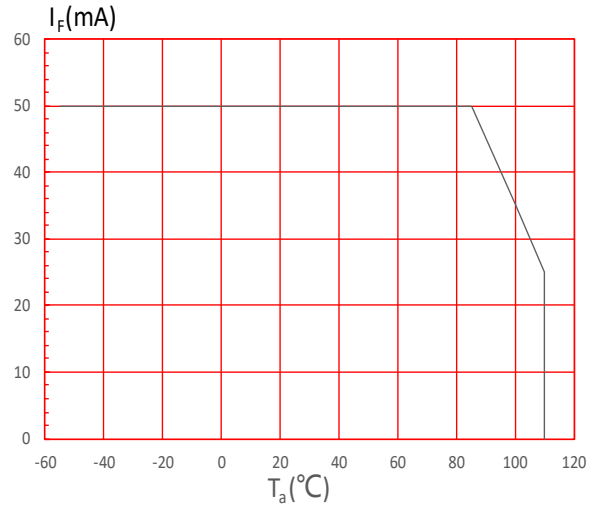

FIG.3: Logic High Output Supply Current vs. Ambient Temperature

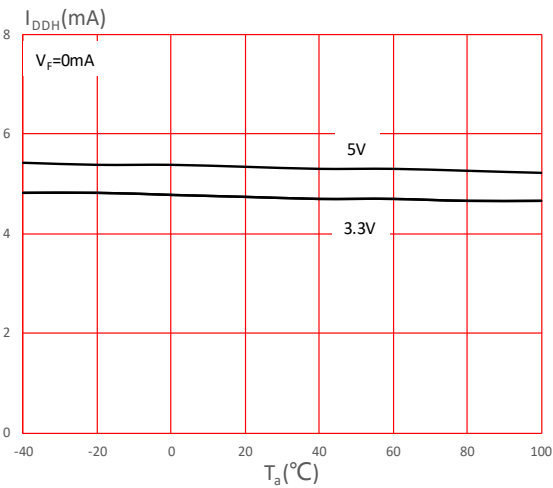

FIG.4: Logic Low Output Supply Current vs. Ambient Temperature

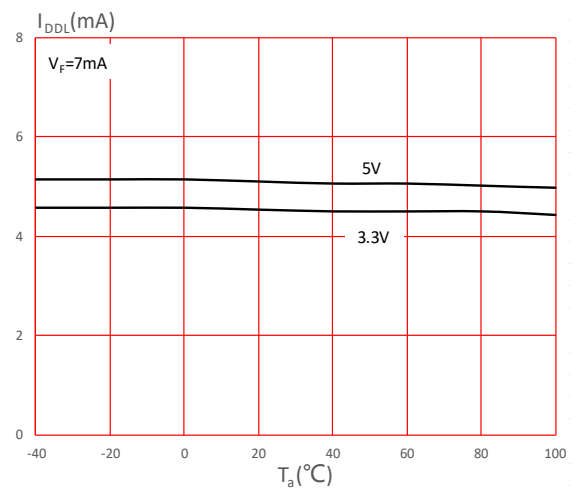

FIG.5: Propagation Delay vs. Ambient Temperature

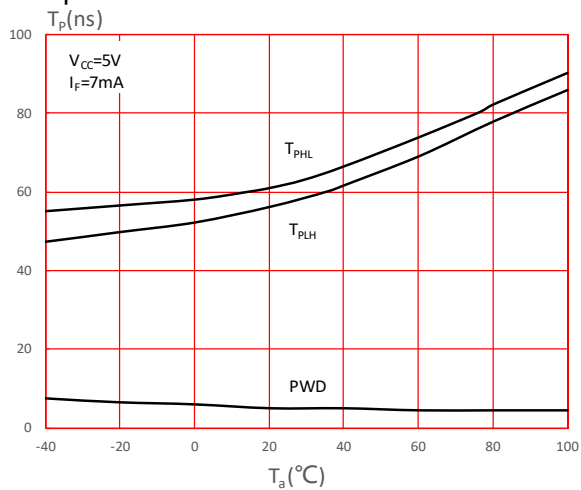

FIG.6: Input Threshold Current vs. Ambient Temperature

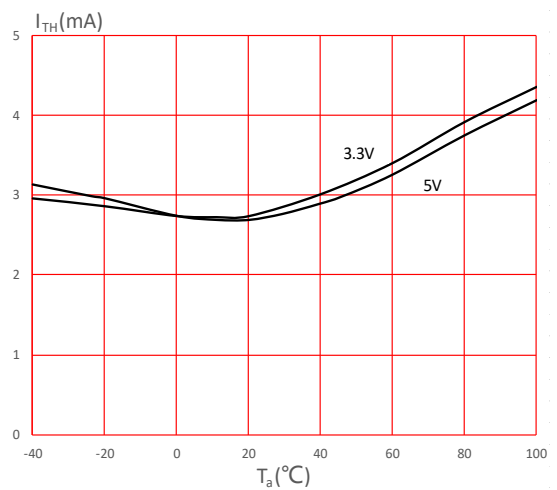

FIG.7: Propagation Delay vs. Ambient Temperature

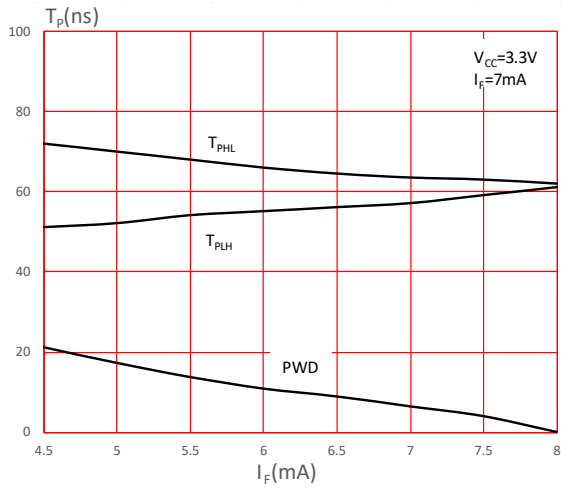
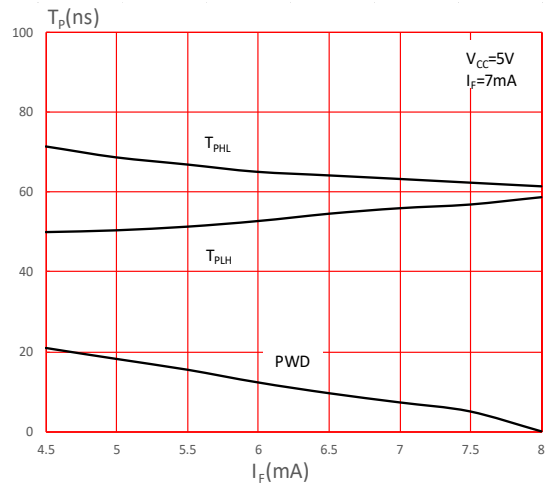

FIG.8: Propagation Delay vs. Ambient Temperature



TEST CIRCUITS

Fig.9: Test Circuits for TPHL, TPLH, tr, tf

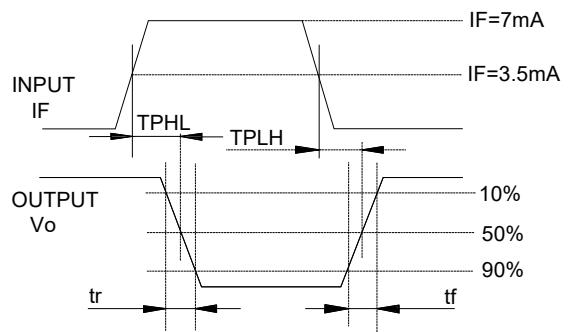
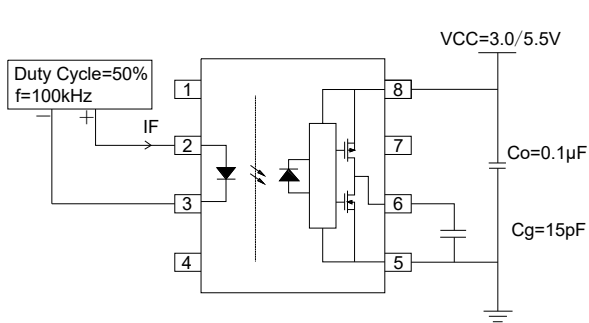
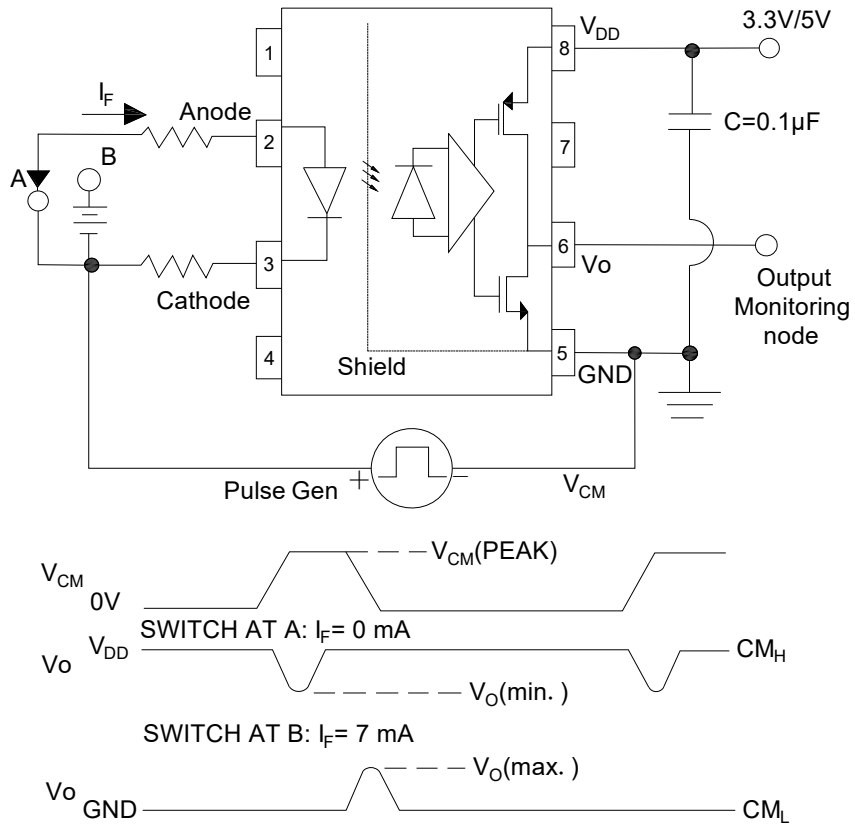
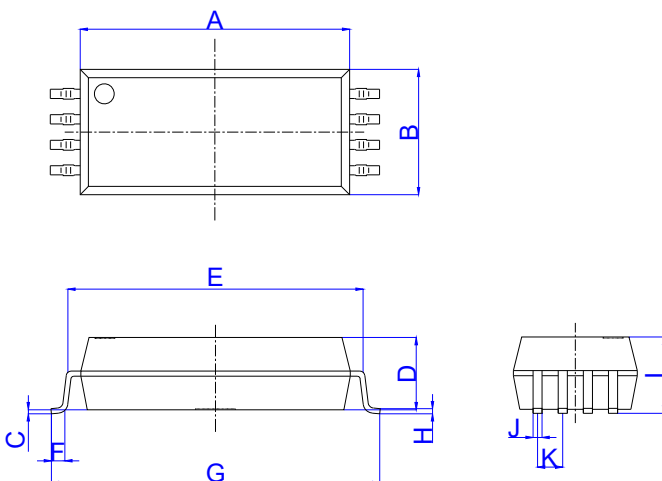

Fig.10: CMTI Test Circuit Recommendations



Package Dimension (Unit: mm)



Ref.	Dimensions					
	Millimeters			Inches		
	Min.	Typ.	Max.	Min.	Typ.	Max.
A	13.50		13.70	0.531		0.539
B	6.15		6.35	0.242		0.250
C	0.10		0.30	0.004		0.012
D	3.50		3.70	0.138		0.146
E	14.71		15.31	0.579		0.603
F	0.52		1.02	0.020		0.040
G	16.36		16.86	0.644		0.664
H	0.10		0.40	0.004		0.016
I	3.65		3.95	0.144		0.156
J	0.307		0.607	0.012		0.024
K	1.02		1.52	0.040		0.060

RECOMMENDED SOLDER MASK (Dimensions in mm unless otherwise stated)

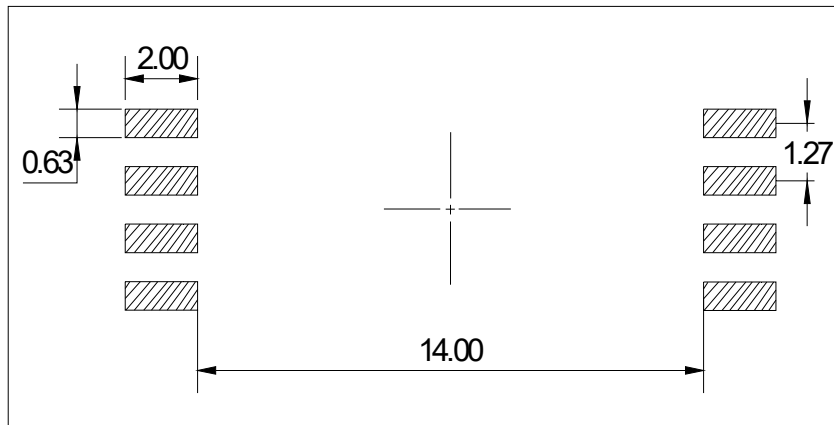

CARRIER TAPE SPECIFICATIONS (Dimensions in mm unless otherwise stated)

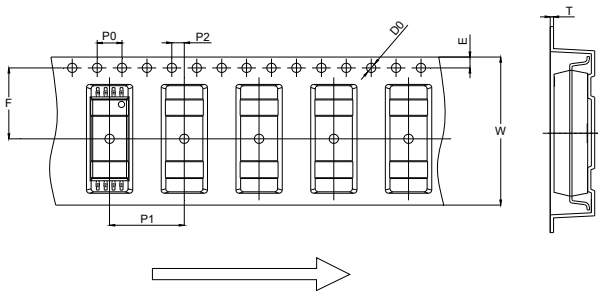

Ref.	Dimensions					
	Millimeters			Inches		
	Min.	Typ.	Max.	Min.	Typ.	Max.
D0	1.40	1.50	1.60	0.055	0.059	0.063
P0	3.90	4.00	4.10	0.154	0.157	0.161
P1	11.90	12.00	12.10	0.469	0.472	0.476
P2	1.90	2.00	2.10	0.075	0.079	0.083
E	1.65	1.75	1.85	0.065	0.069	0.073
F	11.40	11.50	11.60	0.449	0.453	0.457
T	0.35	0.40	0.45	0.014	0.016	0.018
W	23.70	24.00	24.30	0.933	0.945	0.957

REFLOW INFORMATION

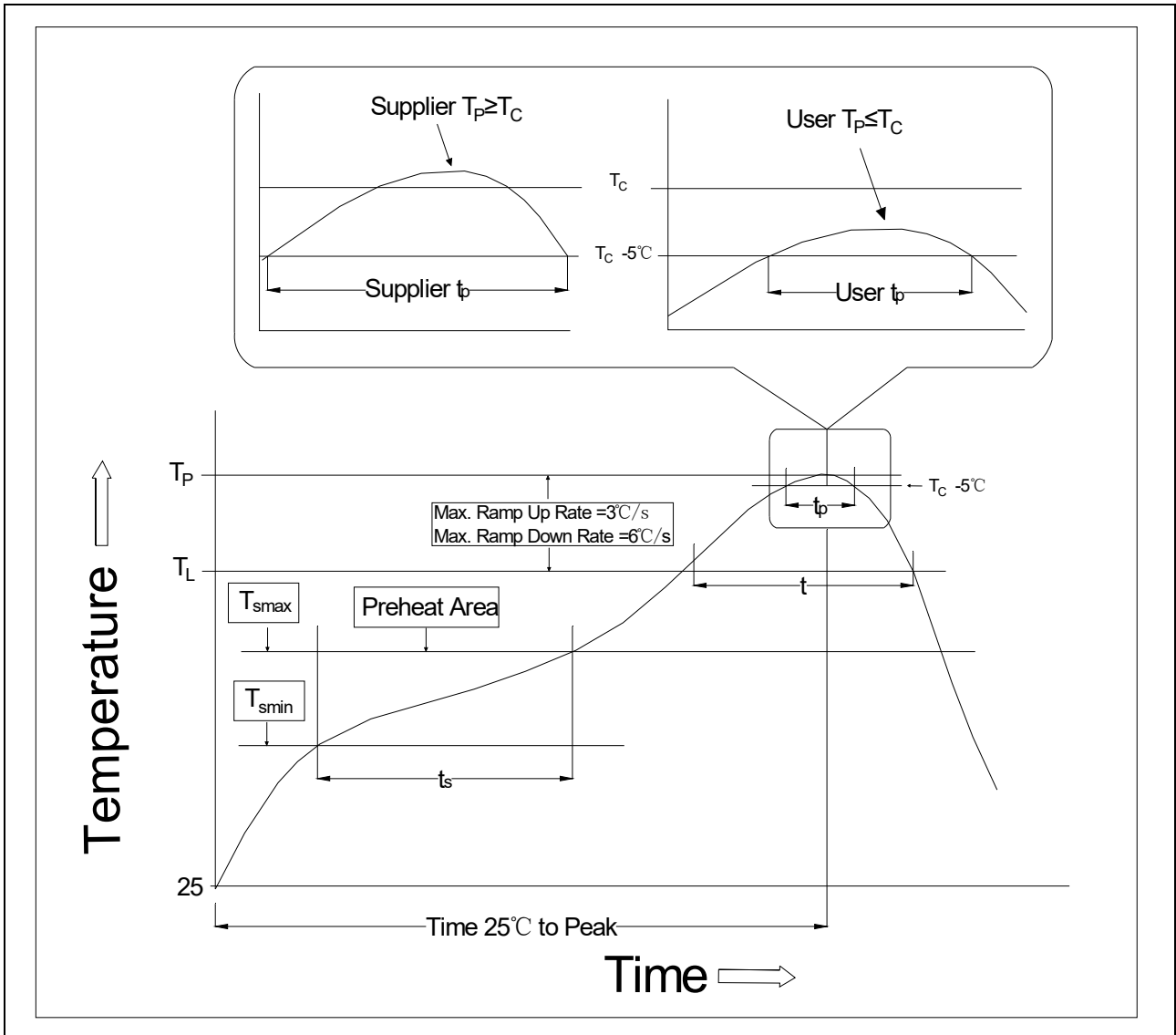

Profile Feature	Sn-Pb Assembly Profile	Pb-Free Assembly Profile
Temperature Min. (T _{smin})	100	150°C
Temperature Max. (T _{smax})	150	200°C
Time (t _s) from (T _{smin} to T _{smax})	60-120 seconds	60-120 seconds
Ramp-up Rate (t _L to t _P)	3°C/second max.	3°C/second max.
Liquidus Temperature (T _L)	183°C	217°C
Time (t _L) Maintained Above (T _L)	60-150 seconds	60-150 seconds
Peak Body Package Temperature	235°C+0°C/-5°C	260°C+0°C/-5°C
Time (t _P) within 5°C of 260°C	20 seconds	30 seconds
Ramp-down Rate (T _P to T _L)	6°C/second max.	6°C/second max.
Time 25°C to Peak Temperature	6 minutes max.	8 minutes max.

Note:

1. Reflow soldering is recommended at the temperatures and times shown, no more than three times.
2. Avoid direct contact between the epoxy body and any tools or surfaces exceeding its maximum storage temperature.
3. Application of pressure on the epoxy body is prohibited at elevated temperatures. In specific scenarios, any applied force must not exceed 2.5N.
4. Ensure the component has cooled to ambient temperature before proceeding with any subsequent manufacturing steps.
5. The component has a shelf life of one year when stored under standard conditions.
6. Recommend storage Temp.: 0~40°C;
Recommend storage humidity: <60%;
MSL level: MSL 1

Information furnished in this document is believed to be accurate and reliable. However, Jiangsu JieJie Microelectronics Co., Ltd. assumes no responsibility for the consequences of use without consideration for such information nor use beyond it. Information mentioned in this document is subject to change without notice, apart from that when an agreement is signed, Jiangsu JieJie complies with the agreement.

Products and information provided in this document have no infringement of patents. Jiangsu JieJie assumes no responsibility for any infringement of other rights of third parties which may result from the use of such products and information. This document supersedes and replaces all information previously supplied.

 is a registered trademark of Jiangsu JieJie Microelectronics Co., Ltd.

Copyright © 2026 Jiangsu JieJie Microelectronics Co., Ltd. All rights reserved.