



JOCSZ2XBM-D7P/S Series

Rev.A.1.0

DESCRIPTION:

The products are 7-pin solid-state relay opto-couplers. The device combines an AlGaAs infrared emitting diode as the emitter which is optically coupled to a monolithic silicon zero-crossing photo triac to drive a power triac in a plastic DIP7 package with different lead forming options.

The products are widely used in solenoid/valve controls, lighting controls, motor controls, temperature controls, static AC power switches, solid state relays, interfacing microprocessors to 265 V_{AC} peripherals.

MAIN FEATURES:

- High isolation 5000 Vrms
- DC input with triac output
- Operating temperature range - 40°C to 110 °C
- REACH & RoHS compliance
- HBM: H3B; MM: M4; CDM:C3
- CQC approved
- VDE approved
- UL approved

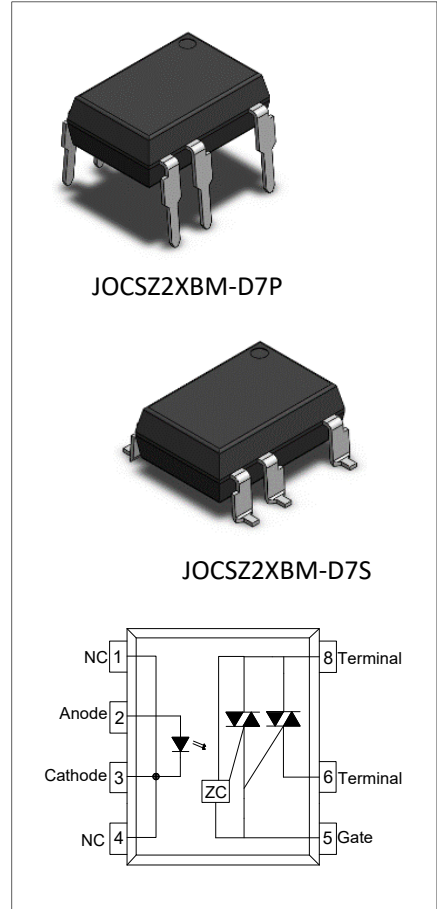

ABSOLUTE MAXIMUM RATINGS (Temperature=25°C)

Parameter		Symbol	Value	Unit	
Input	Forward Current	I _F	50	mA	
	Peak Forward Current	I _{FP}	1 ^①	A	
	Reverse Voltage	V _R	6	V	
	Power Dissipation	P _D	75	mW	
Output	Repetitive peak off-state voltage	V _{DRM}	600	V	
	Repetitive peak reverse voltage	V _{RRM}	600	V	
	Critical rate of rise of on-state current	di/dt	100	A/μs	
	On-state RMS Current	JOCSZ23BM (T _a ≤96°C)	I _{T(RMS)}	0.3	A
		JOCSZ26BM (T _a ≤76°C)		0.6	
JOCSZ29BM (T _a ≤58°C)		0.9			
JOCSZ2BBM (T _a ≤40°C)		1.2			

Non repetitive surge peak on-state current (full cycle , $t_p=20ms$)	JOCSZ23BM	I_{TSM}	3	A
	JOCSZ26BM		6	
	JOCSZ29BM		9	
	JOCSZ2BBM		12	
junction to case (AC)		$R_{th(j-c)}$	40	$^{\circ}C/W$
Isolation Voltage		V_{iso}	5000 ^②	V_{rms}
Operating Temperature		T_{opr}	-40~110	$^{\circ}C$
Junction Temperature		T_j	125	$^{\circ}C$
Storage Temperature		T_{stg}	-40~125	$^{\circ}C$
Soldering Temperature		T_{sol}	260	$^{\circ}C$
Peak pulse voltage ($T_j=25^{\circ}C$; non-repetitive,off-state)		V_{pp}	3	kV

NOTE1 : 100 μs pulse, 100Hz frequency

NOTE2 : AC for 1minute, R.H.=40~60%

ELECTRICAL CHARACTERISTICS (Temperature=25 $^{\circ}C$)

Parameter		Symbol	Condition	Min.	Typ.	Max.	Unit	
Input	Forward Voltage	V_F	$I_F=10mA$	-	1.2	1.5	V	
	Reverse Current	I_R	$V_R=6V$	-	-	1	μA	
Output	Peak Off-state Current, Either Direction	I_{DRM}	$V_{DRM} / V_{RRM} = 600V, I_F=0$	-	-	5	μA	
		I_{RRM}		-	-	5		
	Peak On-state Voltage, Either Direction	JOCSR23BM	V_{TM}	$I_{TM}=0.3A$	-	-	1.2	V
		JOCSR26BM		$I_{TM}=0.6A$	-	-	1.4	
		JOCSR29BM		$I_{TM}=0.9A$	-	-	1.45	
		JOCSR2BBM		$I_{TM}=1.2A$	-	-	1.5	
	Critical Rate of Rise of Off-state voltage		dV/dt	$V_D=400V$, Gate Open $I_F=0$, $T_j=125^{\circ}C$	1000	-	-	$V/\mu s$
Critical Rate of Rise of Commutating Voltage		$(dV/dt)_c$	$(dI/dt)_c = 1.5A/ms$, $T_j=125^{\circ}C$	10	-	-	$V/\mu s$	
Transfer Characteristics	LED Trigger Current	I_{FT}	Terminal Voltage=6V $R_L=100\Omega$	-	-	5	mA	
	Holding Current	I_H	$V_D=6V$	-	-	25	mA	
	Isolation Resistance	R_{iso}	DC500V 40~60%R.H.	10^{12}	10^{14}	-	Ω	

	Response Time	t_{on}	$V_D=6V,$ $R_L=100\Omega,$ $I_F=20mA$	-	20	100	μs
Zero Crossing	Inhibit Voltage	V_{IH}	$I_F=10mA$	-	-	20	V
	Leakage in Inhibit State	I_{DRM2}	$I_F=10mA,$ $V_{DRM}=600V$	-	-	500	μA

ORDERING INFORMATION

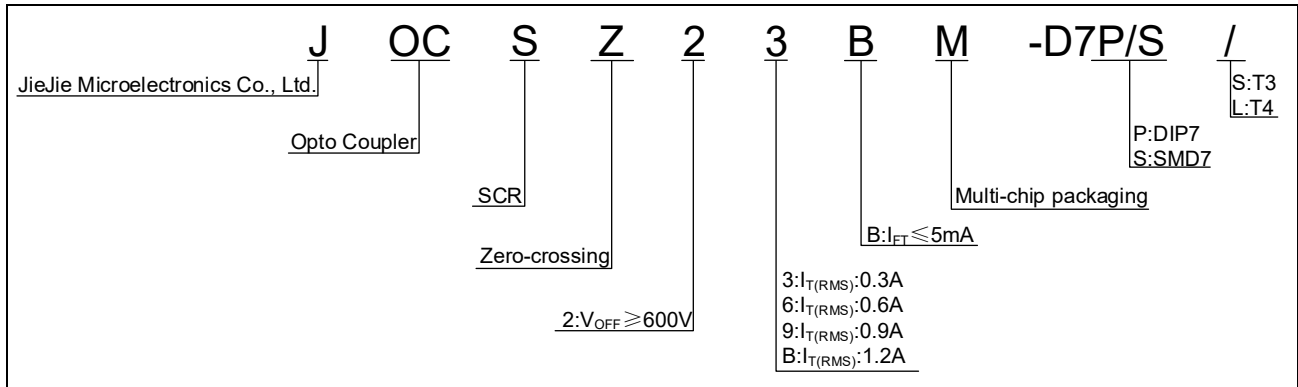

Packing Quantity	
Option	Quantity
DIP	50 Units/Tube
SMD	1200 Units/Reel

MARKING

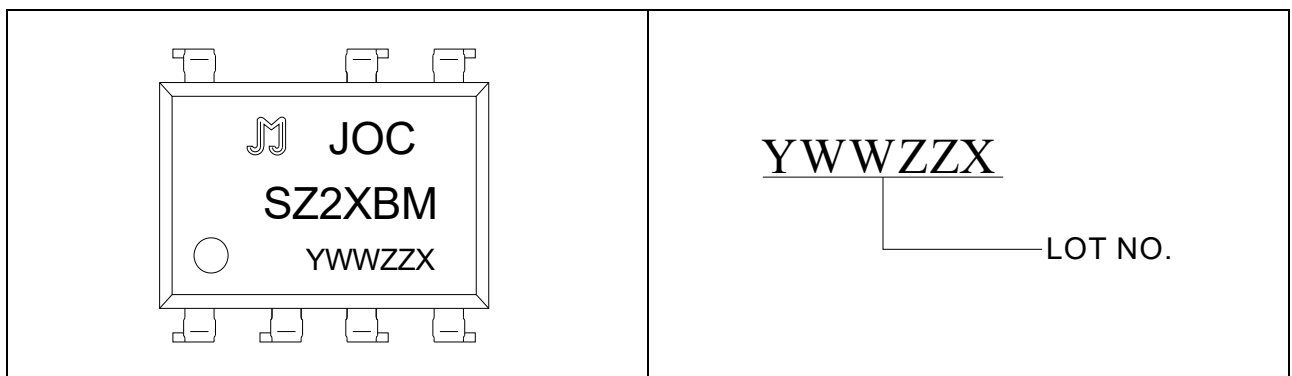

Characteristics Curves

FIG.1: Max. Allowable LED Forward Current vs. Ambient Temperature

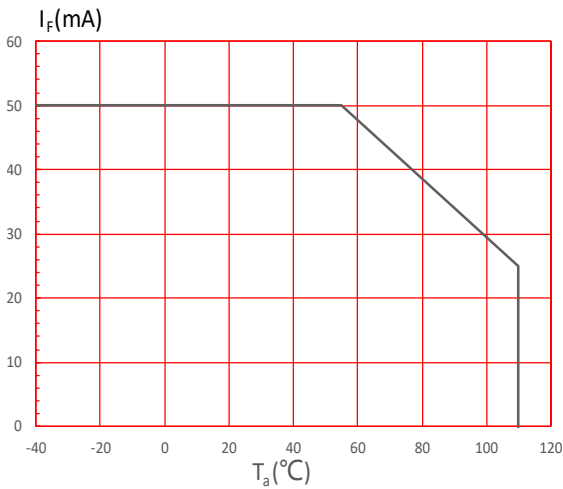

FIG.3: Forward Current vs. Forward Voltage

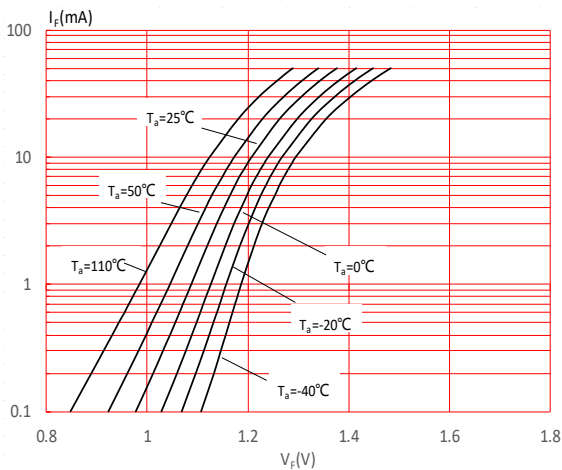

FIG.5: Off-state Terminal Current vs. Off-state Terminal Voltage

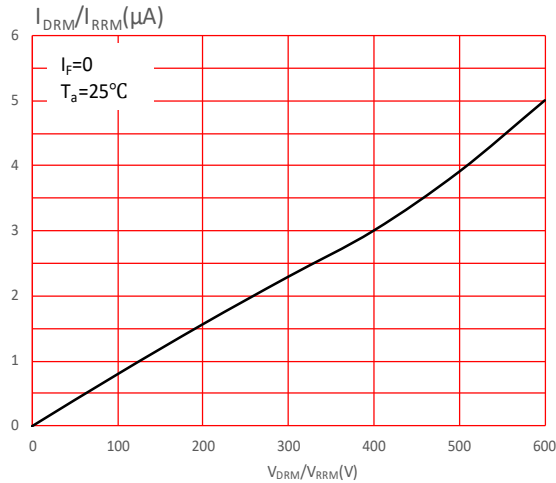

FIG.2: On-state Terminal Current vs. Ambient Temperature

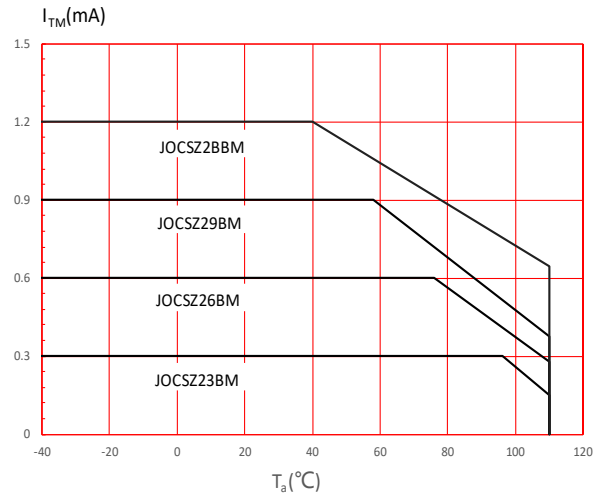

FIG.4: Forward Voltage vs. Ambient Temperature

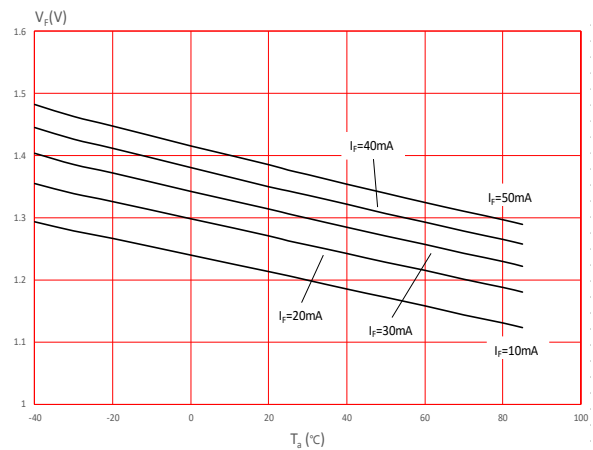

FIG.6: Normalized Trigger Current vs. Ambient Temperature

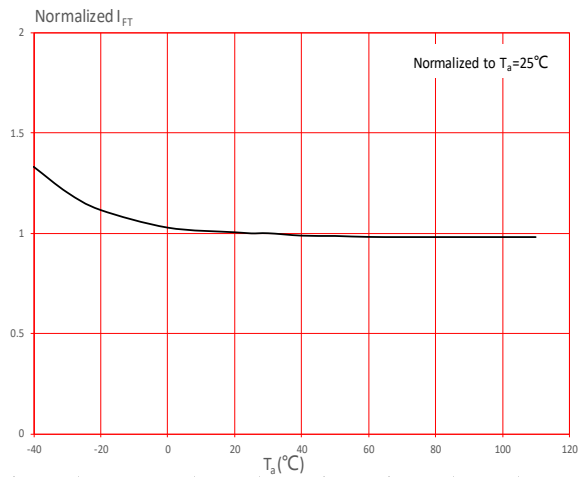

FIG.7: On-state characteristics

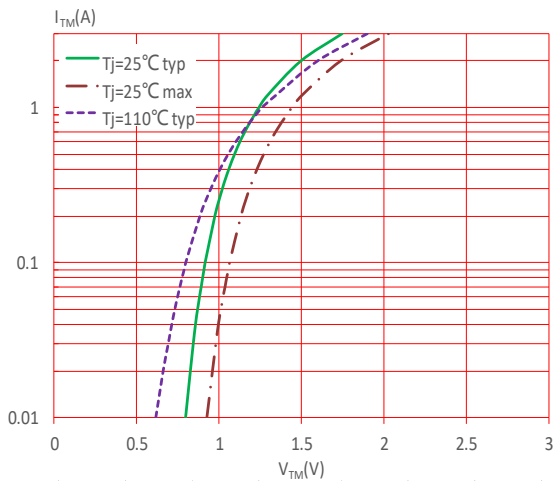

FIG.8: Normalized Holding Current vs. Ambient Temperature

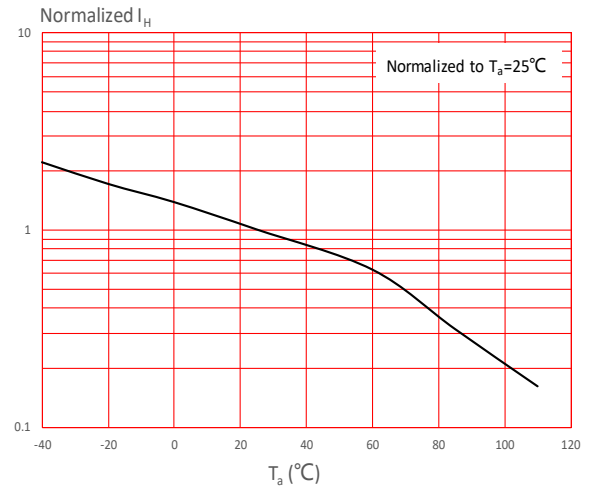

FIG.9: Turn On Time vs. Forward Current

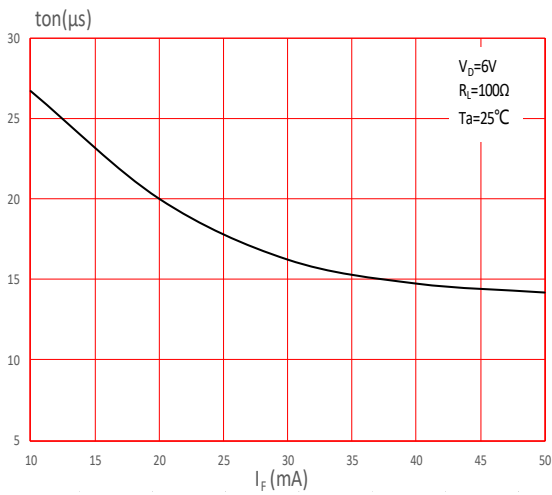
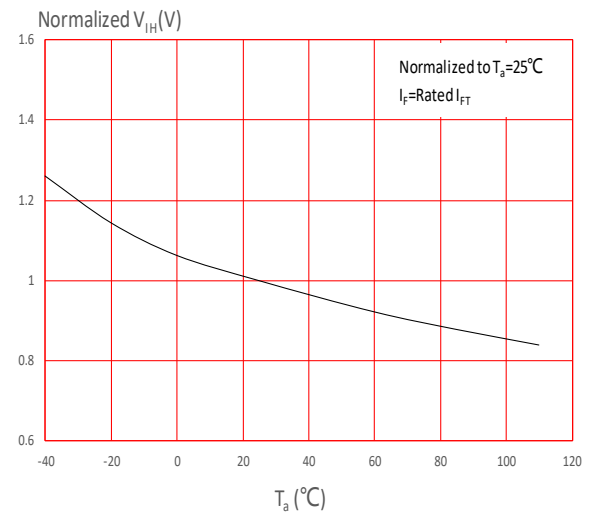

FIG.10: Normalized Inhibit Voltage vs. Ambient Temperature



TEST CIRCUITS

FIG.11: Test Circuits of Turn On Time

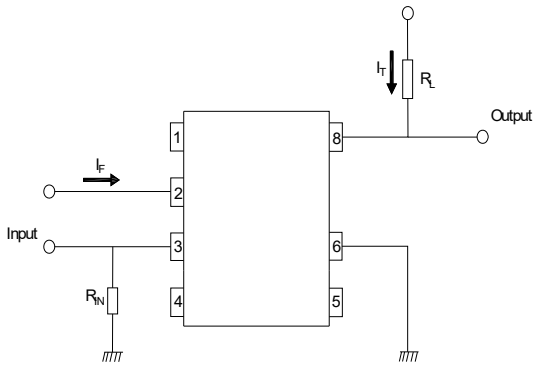
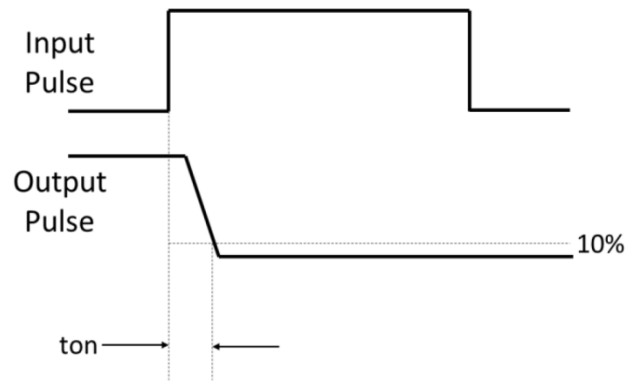
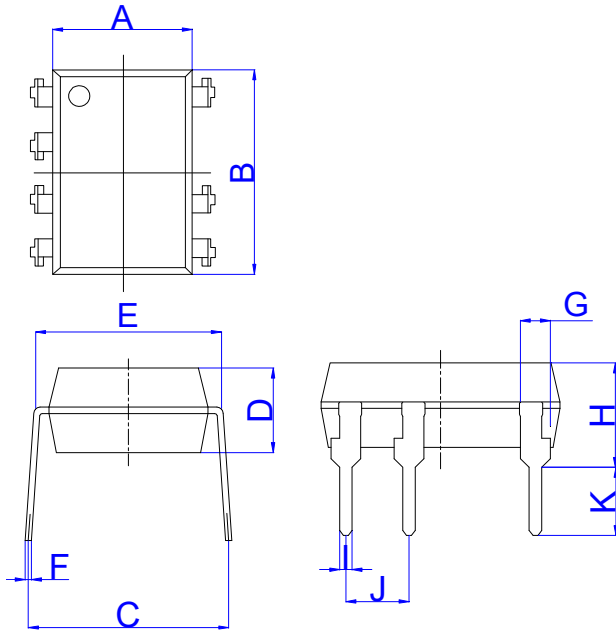

FIG.12: Waveforms of Turn On Time



Package Dimension (Unit: mm)

Standard DIP Type:



Ref.	Dimensions					
	Millimeters			Inches		
	Min.	Typ.	Max.	Min.	Typ.	Max.
A	6.20		6.60	0.244		0.260
B	9.40		9.80	0.370		0.386
C	7.15		8.95	0.281		0.352
D	3.20		3.60	0.126		0.142
E	7.32		7.92	0.288		0.312
F	0.15		0.35	0.006		0.014
G	0.90		1.50	0.035		0.059
H	3.90		4.50	0.154		0.177
I	0.40		0.60	0.016		0.024
J	2.29		2.79	0.090		0.110
K	2.24		3.24	0.088		0.128

Option SMD Type:

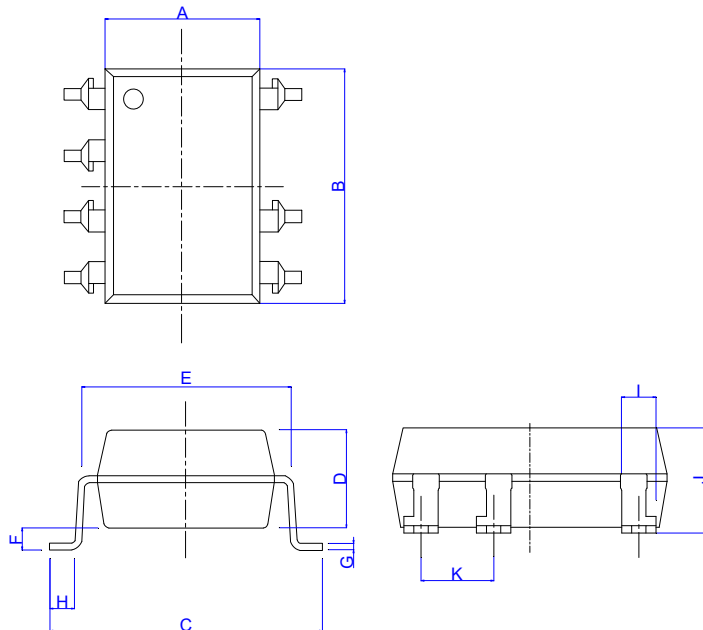

Ref.	Dimensions					
	Millimeters			Inches		
	Min.	Typ.	Max.	Min.	Typ.	Max.
A	6.20		6.60	0.244		0.260
B	9.40		9.80	0.370		0.386
C	9.50		10.50	0.374		0.413
D	3.20		3.60	0.126		0.142
E	7.32		7.92	0.288		0.312
F	0.05		0.35	0.002		0.014
G	0.16		0.36	0.006		0.014
H	0.60		1.40	0.024		0.055
I	0.90		1.50	0.035		0.059
J	3.30		3.90	0.130		0.154
K	2.29		2.79	0.090		0.110

RECOMMENDED SOLDER MASK (Dimensions in mm unless otherwise stated)

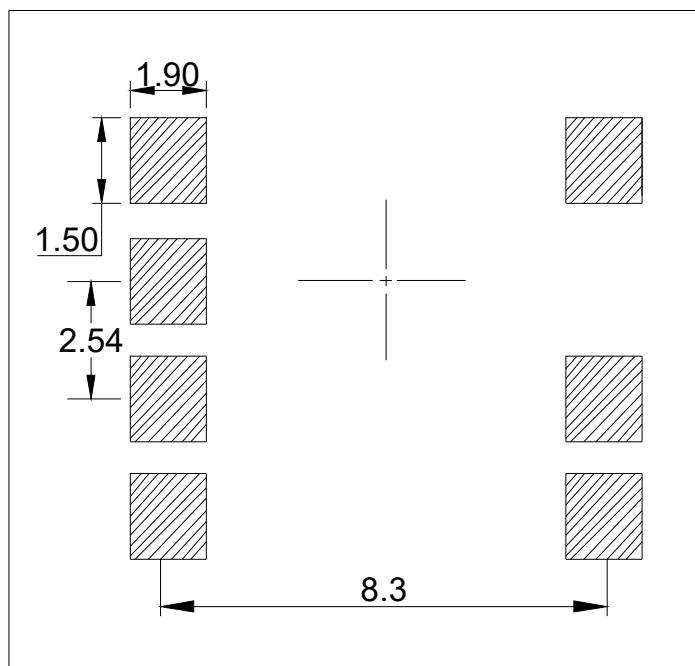

CARRIER TAPE SPECIFICATIONS (Dimensions in mm unless otherwise stated)

Option S/L

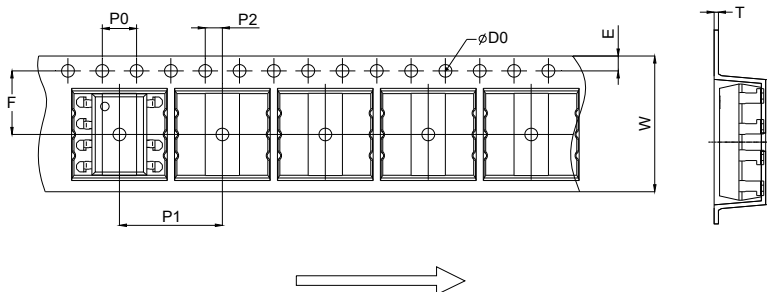

Ref.	Dimensions					
	Millimeters			Inches		
	Min.	Typ.	Max.	Min.	Typ.	Max.
D0		1.50	1.60		0.059	0.063
P0	3.90	4.00	4.10	0.154	0.157	0.161
P1	11.90	12.00	12.10	0.469	0.472	0.476
P2	1.90	2.00	2.10	0.075	0.079	0.083
E	1.65	1.75	1.85	0.065	0.069	0.073
F	7.40	7.50	7.60	0.291	0.295	0.299
T	0.35	0.40	0.45	0.014	0.016	0.018
W	15.90	16.00	16.20	0.626	0.630	0.638

REFLOW INFORMATION

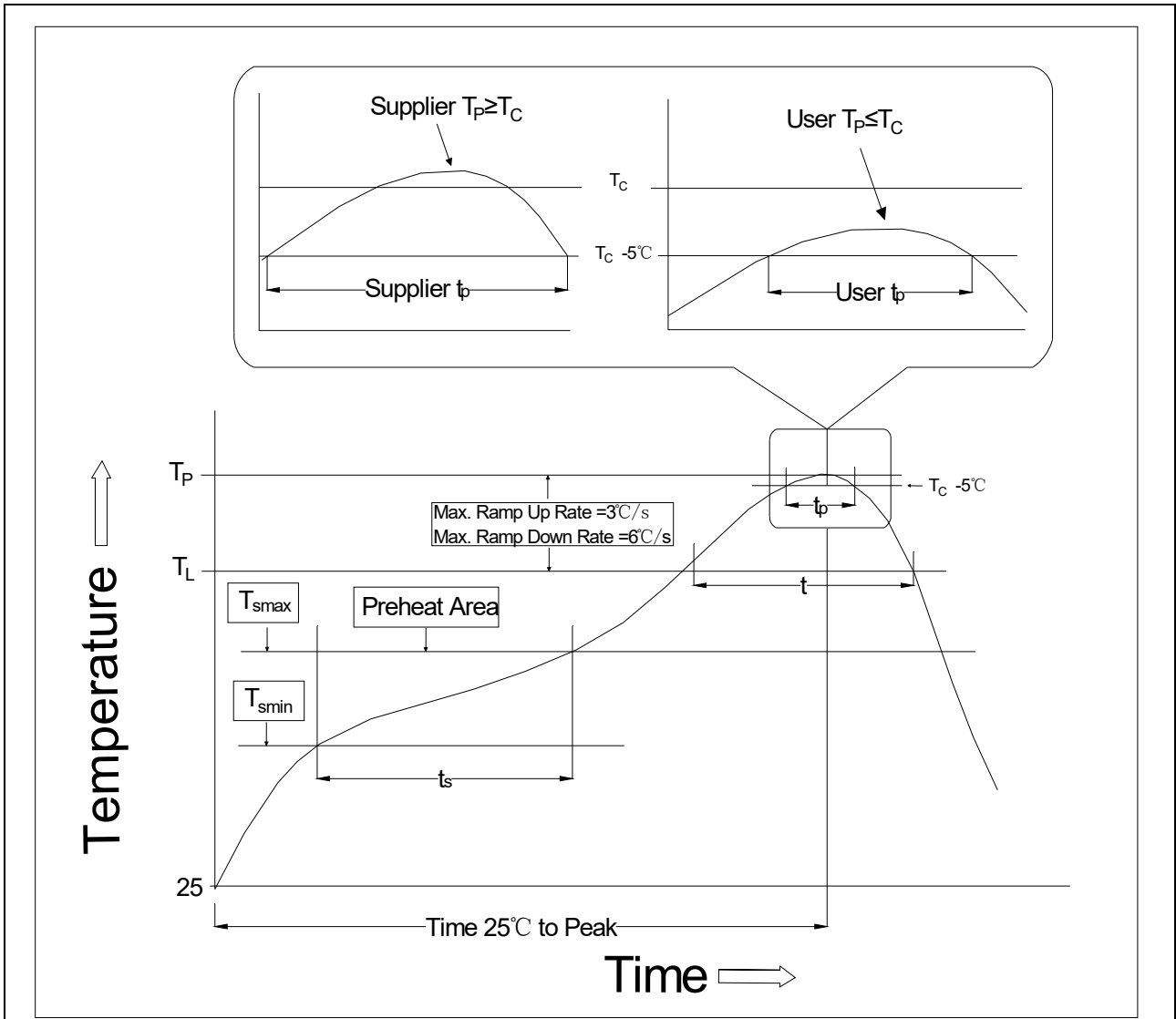

Temperature Min. (T _{smin})	150 °C
Temperature Max. (T _{smax})	200 °C
Time (t _s) from (T _{smin} to T _{smax})	60-120 seconds
Ramp-up Rate (t _L to t _P)	3°C/second max.
Liquidous Temperature (T _L)	217 °C
Time (t _L) Maintained Above (T _L)	60-120 seconds
Peak Body Package Temperature	260 °C +0 °C / -5 °C
Time (t _P) within 5 °C of 260 °C	10 seconds
Ramp-down Rate (T _P to T _L)	6°C/second max.

WAVE SOLDERING

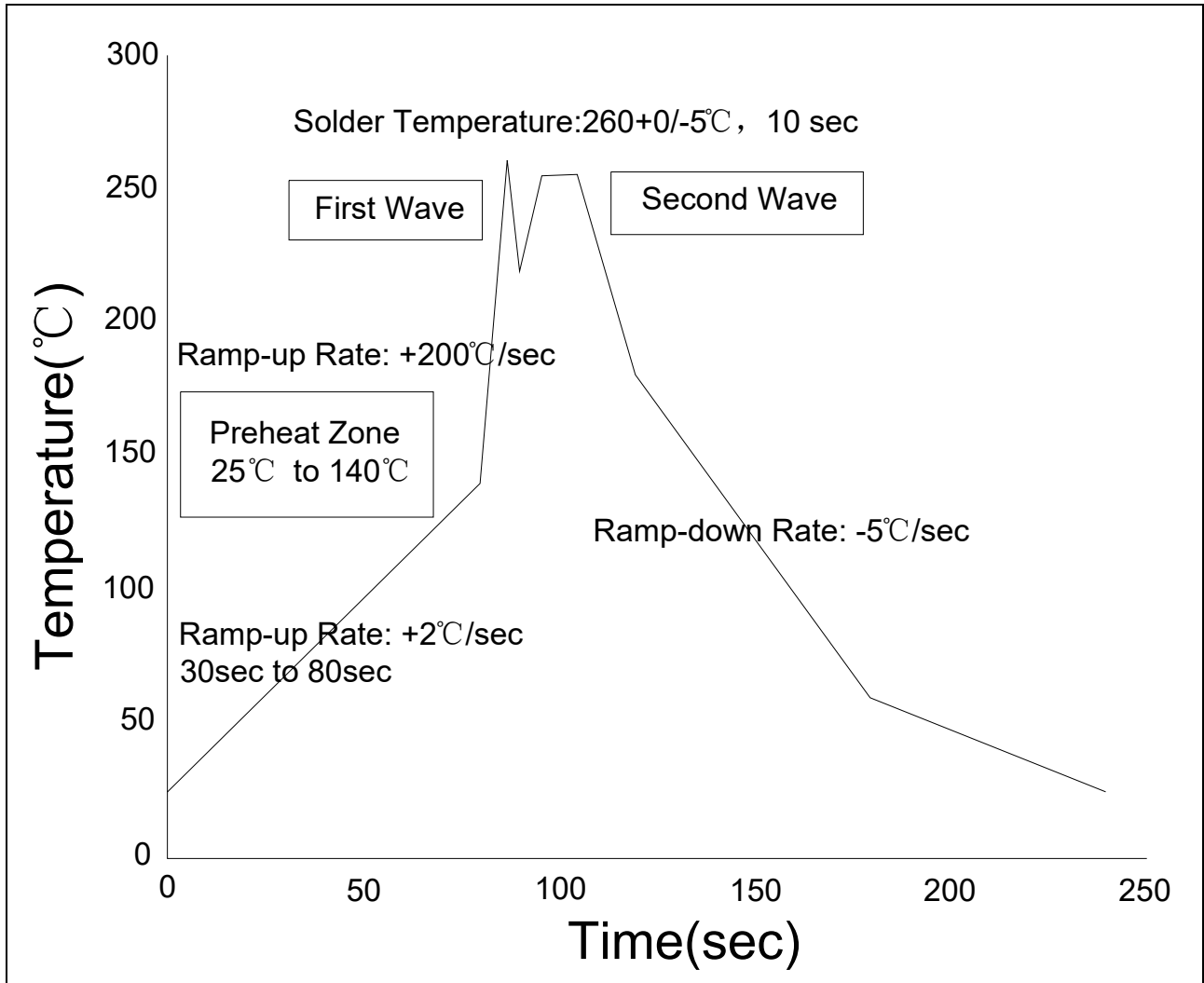

HAND SOLDERING BY SOLDERING IRON

Soldering Temperature	$360 \pm 5^{\circ}\text{C}$
Soldering Time	3s max.

Note:

1. Reflow soldering is recommended at the temperatures and times shown, no more than three times.
2. Avoid direct contact between the epoxy body and any tools or surfaces exceeding its maximum storage temperature.
3. Application of pressure on the epoxy body is prohibited at elevated temperatures. In specific scenarios, any applied force must not exceed 2.5N.
4. Ensure the component has cooled to ambient temperature before proceeding with any subsequent manufacturing steps.
5. The component has a shelf life of one year when stored under standard conditions.
6. Recommend storage Temp.: 0~40°C;
Recommend storage humidity: <60%;
MSL level: MSL 1

Information furnished in this document is believed to be accurate and reliable. However, Jiangsu JieJie Microelectronics Co., Ltd. assumes no responsibility for the consequences of use without consideration for such information nor use beyond it. Information mentioned in this document is subject to change without notice, apart from that when an agreement is signed, Jiangsu JieJie complies with the agreement.

Products and information provided in this document have no infringement of patents. Jiangsu JieJie assumes no responsibility for any infringement of other rights of third parties which may result from the use of such products and information. This document supersedes and replaces all information previously supplied.

 is a registered trademark of Jiangsu JieJie Microelectronics Co., Ltd.

Copyright © 2026 Jiangsu JieJie Microelectronics Co., Ltd. All rights reserved.